

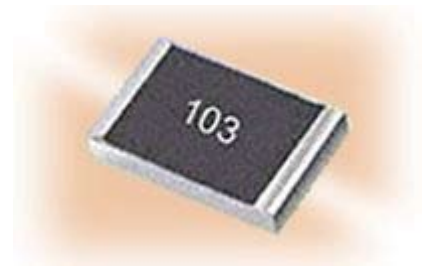

Chip Resistor

FCR, RCA, RCN SMD Resistors / 贴片电阻

FCR, RCA, RCN Series Resistor are formed by vacuum depositing a resistive alloy on a usually flat substrate of ceramic. Photo-lithographic or similar techniques are used to define the final geometry and interconnecting traces. This technology provides for close ratio matching and tracking in a network, as well as low stand-alone temperature coefficient and resistance tolerance. Types includes precision smd (FCR), smd array (RCA), and networks (RCN).



► Chip Thick Film Dimension (Unit: mm)

Type	L	W	H	L1	L2
FCR 03	1.60 ± 0.10	0.80 ± 0.10	0.45 ± 0.10	0.30 ± 0.20	0.30 ± 0.20
FCR 05	2.00 ± 0.15	1.25 ± 0.15	0.50 ± 0.10	0.40 ± 0.20	0.35 ± 0.15
FCR 06	3.10 ± 0.15	1.55 ± 0.15	0.55 ± 0.10	0.50 ± 0.25	0.50 ± 0.25

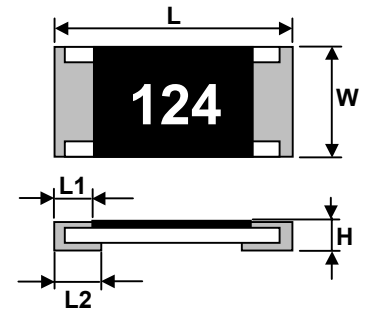

► Chip Thick Film Characteristic

Type	Power Rating at 70°C	Max. RCWV	Max. Overload Voltage	Resistance Tolerance(%)	Resistance Range (Ω)		Standard Resistance Values
					Min.	Max.	
FCR03	1/10W	50V	100V	± 1% (F)	10Ω	1MΩ	E-96
				± 5% (J)	1Ω	10MΩ	E-24
FCR05	1/8W	150V	300V	± 1% (F)	10Ω	1MΩ	E-96
				± 5% (J)	1Ω	10MΩ	E-24
FCR06	1/4W	200V	300V	± 1% (F)	10Ω	1MΩ	E-96
				± 5% (J)	1Ω	10MΩ	E-24

► Chip Array Dimension (Unit: mm)

Type	L	W	H	L1	L2	P	Q
RCA03-4D(0603)	3.2±0.2	1.6±0.15	0.5±0.1	0.30±0.15	0.35Max	0.8±0.1	0.5±0.1

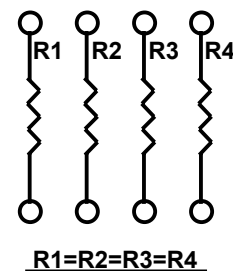
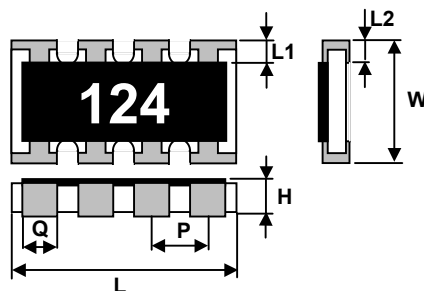

► Chip Array Characteristic

Type	Rated Power at 70°C	Max. Working Voltage	Max. Overload Voltage	T.C.R. (ppm/°C)	Resistance Range		Jumper Rated Current	Jumper Resistance Value	Operating Temperature Range
					F(±1%) E-96	G(±2%) J(±5%) E-24			
RCA03-4D (0603)	0.063	50V	100V	± 200	100Ω~470KΩ	10Ω~1MΩ	1A	50mΩ MAX	-55°C~+125°C



Chip Resistor

► Chip Network Dimension (Unit: mm)

Type	L	W	H	L1	L2	P	Q
RCN06-10R RCN06-10S	6.4 ± 0.2	3.1 ± 0.2	0.55 ± 0.1	0.5 ± 0.3	0.5 ± 0.2	1.27 ± 0.1	0.8 ± 0.2

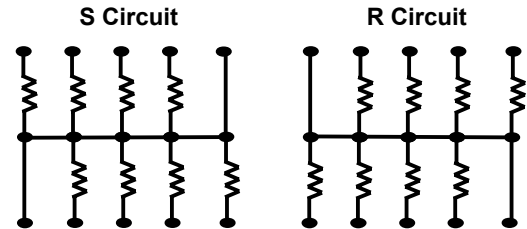
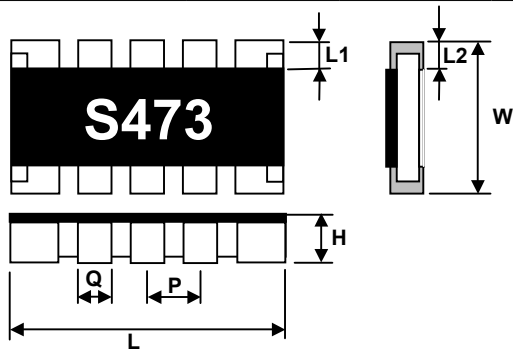

► Chip Network Characteristic

Type	Rated Power at 70°C	Max. Working Voltage	Max. Overload Voltage	T.C.R. (ppm/°C)	Resistance Range	Number of Terminals	Number of Elements	Operating Temperature Range
					J (±5%) E-12			
RCN06-10R RCN06-10S	1/16W	50V	100V	±200	10Ω~1MΩ	10	8	-55°C~+125°C

► Chip Specifications

Item	Specification	Test Method
DC Resistance	J: ±5%, F: ±1%	JIS C 5202 5.1
Temperature Coefficient of Resistance(TCR)	J: ±200ppm/°C F: ±100ppm/°C	JIS C 5202 5.2 / IEC 115-1 4.8.4.2; T1 T2 Test emperature: 25°C→-55°C 25°C →-55°C
Short Time Overload	J:ΔR≤±(2%+0.1Ω) F:ΔR≤±(1%+0.05Ω)	JIS C 5202 5.5 / IEC 115-1 4.13; 2.5xRated voltage (Max. Overload Voltage) for 5 sec. measure resistance after 30 minutes
Resistance to Solder Heat	J:ΔR≤±(1%+0.1Ω) F:ΔR≤±(0.5%+0.05Ω) No mechanical damage	JIS C 5202 6.4 / IEC 115-1 4.18; With 260 ± 5 °C for 10 ± 1 sec.
Solderability	Over 95% of termination must be covered with solder	JIS C 5202 7.4 / IEC 115-1 4.17; After immersing flux, dip in the 235 ± 5°C molten solderbath for 2 ± 0.5 sec.
Temperature Cycle	J:ΔR≤±(1%+0.1Ω) F:ΔR≤±(0.5%+0.05Ω) No mechanical damage	JIS C 5202 7.4 / IEC 115-1 4.19; Repeat 5 cycles as follow; -55°C(30minutes)+25°C(10~15minutes) +125°C(30minutes)+25°C(10~15minutes)
Terminal Strength	ΔR≤±(0.5%+0.05Ω) No mechanical damage	JIS C 5202 6.1; 500g for 10 seconds
Load Life	J:ΔR≤±(3%+0.1Ω) F:ΔR≤±(1%+0.05Ω)	JIS C 5202 7.10 / IEC 115-1 4.25.1; Permanent resistance change after 1000+48/-0 hours (1.5 hours ON,0.5hour OFF) at RCWV or Max. Keep the element at 70 ± 3°Cambient
Load Life Humidity	J:ΔR≤±(3%+0.1Ω) F:ΔR≤±(1%+0.05Ω)	JIS C 5202 7.9 / IEC 115-1 4.24.2; Maintain the temperature of the element at 40 ± 2 °Cand 90~95% RH with the ratedvoltage applied. Cycle ON for 1.5hours and Off for 0.5 hour for 1000+48/-0 hours.After one hour, measure the resistance value.
Intermittent Overload	ΔR≤±(5%+0.1Ω) No mechanical damage	JIS C 5202 5.8; 2.5xRated Voltage(Max.OverloadVoltage), 1secON,25sec OFF, test 10,000 cycles



Chip Resistor

► Chip Resistance Marking



3 digit marking
for E24(J)
100~10Ω
122~1.2KΩ
473~47KΩ
105~1MΩ



4 digit marking
for E96(F)
22R1~22.1Ω
1020~102Ω
1542~15.4KΩ



3 digit marking
for E96(F)
02C
 $102 \times 10^2 = 10.2K\Omega$



15E
 $140 \times 10^4 = 1.4M\Omega$

► Chip Characteristic Taping

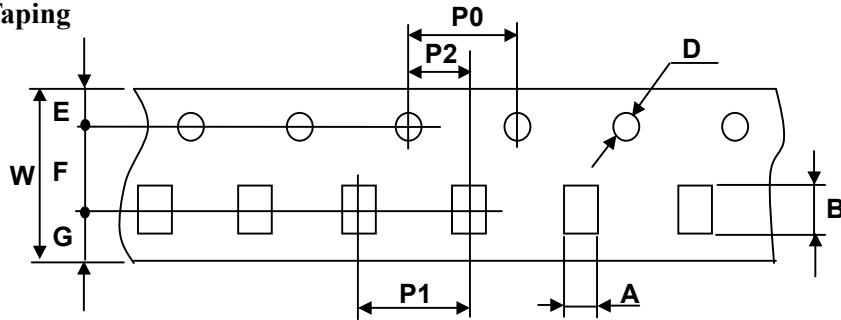

Codes	A	B	W	F	E	P1	P2	P0	D	G
FCR03	1.10±0.20	1.90±0.20	8.0±0.3	3.50±0.05	1.75±0.10	4.0±0.1	2.00±0.05	4.0±0.1	1.5±0.1 -0	2.75
FCR05	1.65±0.20	2.45±0.20	8.0±0.3	3.50±0.05	1.75±0.10	4.0±0.1	2.00±0.05	4.0±0.1	1.5±0.1 -0	2.75
FCR06	2.00±0.10 -0.15	3.57±0.10 -0.15	8.0±0.3	3.50±0.05	1.75±0.10	4.0±0.1	2.00±0.05	4.0±0.1	1.5±0.1 -0	2.75

► Chip Resistors Package

Symbol	Dimension
A	178 ± 2.0
N	80.0 ± 0.5
C	13.0 ± 0.5
D	20min
B	20 ± 0.5
G	100 ± 1.5
T	14.9 max.

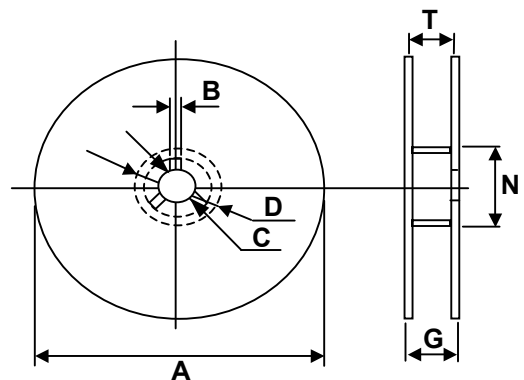

► Part Number Explanation

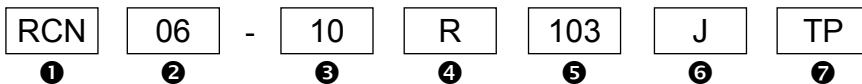

- ① Type: SMDNetwork
- ② Size:06
- ③ Number of Terminals:10
- ④ Circuit Structure;R Circuit,S Circuit
- ⑤ Nominal Resistance

Code	Resistance Tolerance
3-Digit	E12 Series EX 10Ω=100 100Ω=101

⑥ Resistance Tolerance

Code	Resistance Tolerance
J	±5%

⑦ TCR

Code	Packaging
TP	Taping (Paper)
BA	Bulk Case



Chip Resistor

Continued from the preceding page.

Part Number Explanation

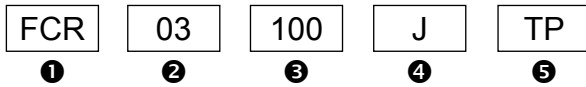

① Type: SMD

② Size

Code	Size
03	0603
05	0805
06	1206

③ Nominal Resistance

Code		
SMD Elements	3-Digit	E24 Series EX 10Ω=100 47Ω=470
	4-Digit	E96 Series EX 10.2Ω=10R2 10KΩ=1002
Jumper		000

④ Resistance Tolerance

Code	Resistance Tolerance
F	±1%
J	±5%

⑤ TCR

Code	Packaging
TP	Taping (Paper)
BA	Bulk Case

Part Number Explanation

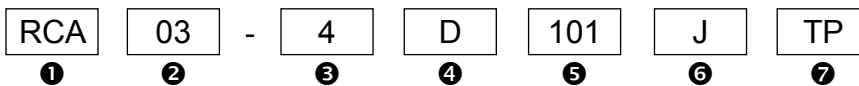

① Type: SMDArray

② Size:03(0603)

③ Number of circuits: 4(4 circuits)

④ Electrode Structure: D(protruding electrode)

⑤ Nominal Resistance

Code		
SMD Elements	3-Digit	E24 Series EX 10Ω=100 47Ω=470
	4-Digit	E96 Series EX 10.2Ω=10R2 10KΩ=1002
Jumper		000

⑥ Resistance Tolerance

Code	Resistance Tolerance
F	±1%
G	±2%
J	±5%

⑦ TCR

Code	Packaging
TP	Taping (Paper)
BA	Bulk Case